

SETUP SHEET

Base Model
 F103 F104 F104W

■ Driver / Hiro Nakatani ■ Date / 2012/09/09 ■ Temp / ■ Humidity / %

■ Track / Rajiten Nagoya in Aichi 【 F1RCGP Round9 】

◆ Location Indoor Outdoor ◆ Size Big Med. Small
 ◆ Road surface Asphalt Carpet ◆ Traction High Med. Low
 ◆ Conditions Smooth Med. Bumpy / Wet

FRONT

◆ SUS ARM TYPE
 F103 F104

◆ F103 / Camber Spacer
 0 mm 1.0 mm 2.0 mm 3.0 mm 4.0 mm 5.0 mm

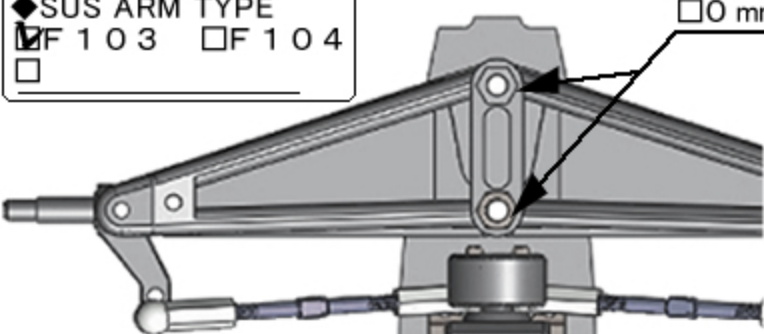

■ Front Wing
 TECH Type-B

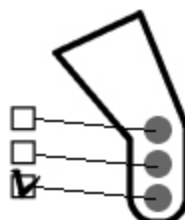
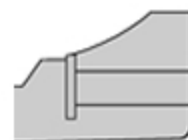

◆ UPRIGHT TYPE
 ■ Maker / Bomber
 InLine
 Trail / 3.6mm

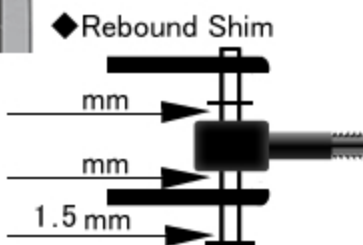

◆ Ackerman

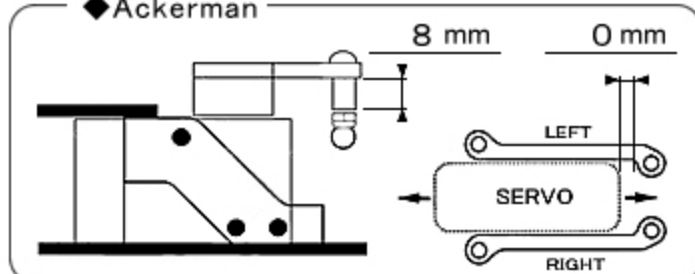

◆ Width / 204 mm ◆ Ride Height / 2 mm
 ◆ Front Spring / HRF024 P-Soft
 ◆ Camber F104
 0° 1.0° 1.5° 2.0° 2.5°
 ◆ Toe IN OUT / 0°
 ◆ Front Tire / ZEN Hi Rubber 49.5mm
 ◆ Additive Yes No
 Maker /
 Time ~ min / Width mm

◆ Notes

rebound stroke 0mm

Rear

■ Rear Damper / AE

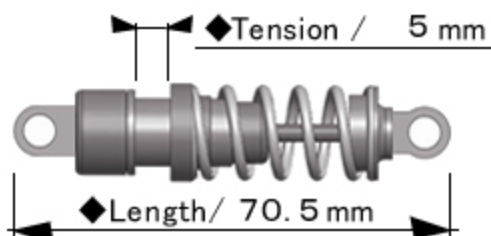

◆ Spring / AE Gold
 ◆ Piston / Hole ◆ Oil / # 500

■ Roll-Damper
 Oil-Damper Tube-Damper
 ◆ Length / mm ◆ Oil / # 3000

◆ Width / 200mm ◆ Ride Height / 2.5mm



◆ Height Adapter
 ◆ Motor mount / HRF025
 H.A. Position / Upper Bottom

◆ Rear Tire / ZEN Soft 48 mm

◆ Additive Yes No
 Maker /

Time ~ min / Width mm

◆ Body / TECH-MG10 Light weight

◆ Rear Wing / TRG

 Height 95 mm

◆ Motor / JET 17.5T

◆ Spur / Pinion / RollOut
 90T / 34T / 56.94

◆ ESC / Hobby Wing

◆ Weight / g

◆ Steering Gyro
 Maker / R246

ON (GAIN 0%)

◆ Notes

GAIN uses 3CH of 4PKS

■ Side Link-Rod

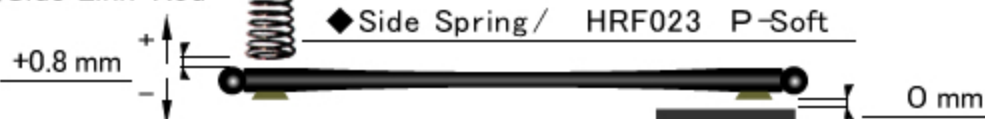

◆ Side Spring / HRF023 P-Soft