

SETUP SHEET

Base Model
 F103 F104 F104W

■ Driver / Hiro Nakatani ■ Date / 2012/04/08 ■ Temp / 25° ■ Humidity / 30 %

■ Track / **K-Stadium in Fukuoka** **GP Class win**

◆ Location Indoor Outdoor ◆ Size Big Med. Small
 ◆ Road surface Asphalt Carpet ◆ Traction High Med. Low
 ◆ Conditions Smooth Med. Bumpy / Wet

FRONT

◆ SUS ARM TYPE
 F103 F104

◆ F103 / Camber Spacer
 0 mm 1.0 mm 2.0 mm 3.0 mm

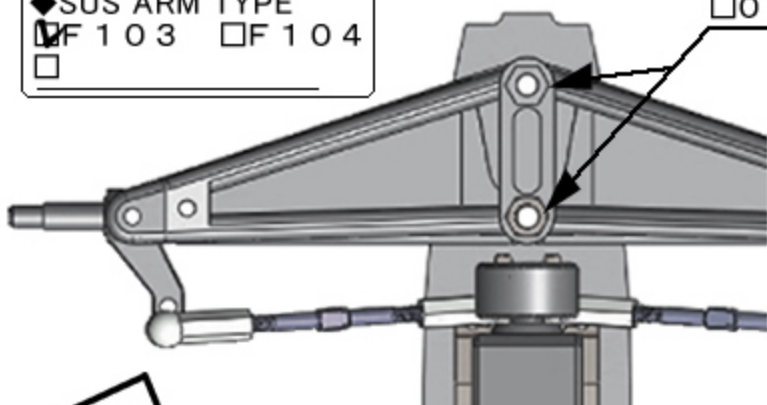

■ Front Wing
 TECH Type-B

An additional flap
 7mm of front area cuts

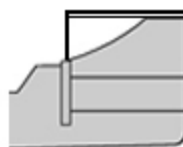

◆ UPRIGHT TYPE
 ■ Maker / Team Bomber
 InLine Trail / 3.6mm

◆ Ackerman

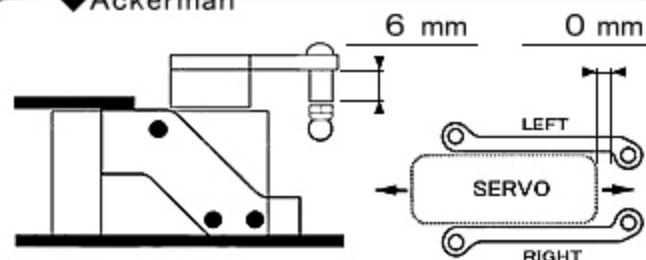

◆ Width / 202 mm ◆ Ride Height / 4 mm

◆ Front Spring / HRF024/P-Soft

◆ Camber F104
 0° 1.0° 1.5° 2.0° 2.5°

◆ Toe IN OUT / 0.5°

◆ Front Tire / ZEN Hi-Rubber 55.5 mm

◆ Additive Yes No
 Maker /

Time ~ min / Width mm

◆ Notes

Rear

■ Rear Damper / AE-R5

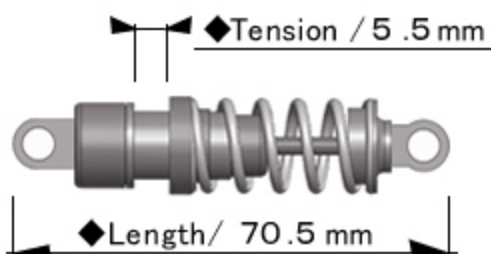

◆ Spring / YOKOMO-R12Black

◆ Piston / Hole ◆ Oil / # 400

■ Roll-Damper

◆ Length / 71.5 mm ◆ Oil / # 100

■ Side Link-Rod

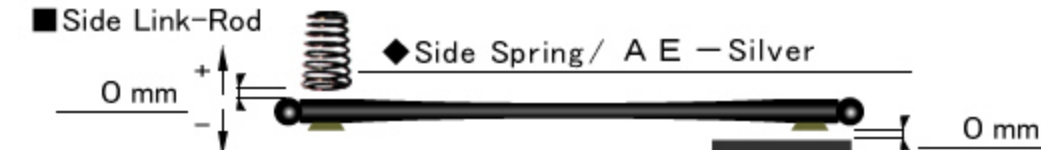

◆ Width / 200 mm

◆ Height Adapter



◆ Ride Height / 4 mm

◆ Rear Tire / ZEN Soft2 5 55 mm

◆ Additive Yes No
 Maker /

Time ~ min / Width

◆ Body / TECH-MG10

◆ Rear Wing / TRG

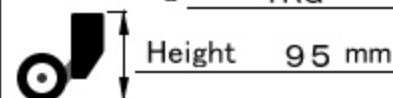

◆ Motor / JET-17.5T

◆ Spur / Pinion / RollOut
 90 T / 31 T / 59.49

◆ ESC / Hobby Wing

◆ Weight / g

◆ Steering Gyro
 Maker / ZEN

ON (GAIN 40 %)

◆ Notes

Moreover, rear grip improves when it adds the post to the center