

SETUP SHEET

Base Model
 F103 F104 F104W

■ Driver / Hiro Nakatani ■ Date / 2012/03/11 ■ Temp / 18° ■ Humidity / 29 %

■ Track / **Big 3 in Tokushima**

◆ Location Indoor Outdoor ◆ Size Big Med. Small
 ◆ Road surface Asphalt Carpet ◆ Traction High Med. Low
 ◆ Conditions Smooth Med. Bumpy / Wet

FRONT

◆ SUS ARM TYPE
 F103 F104

◆ F103 / Camber Spacer
 0 mm 1.0 mm 2.0 mm 3.0 mm

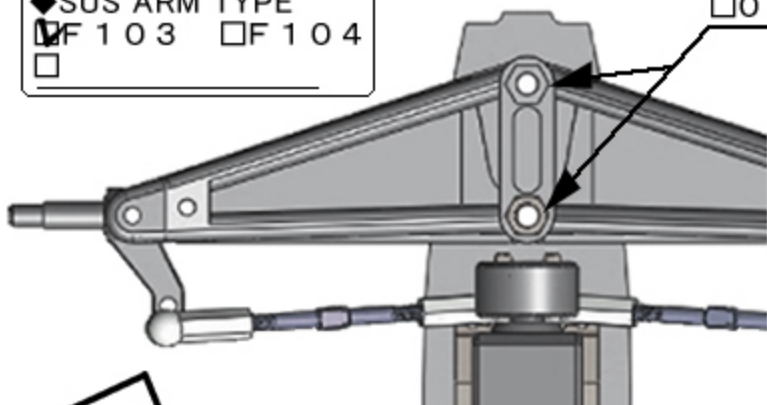

■ Front Wing
 TECH Type-B

An additional flap
 7mm of front area cuts

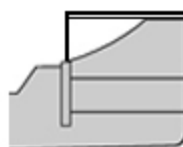

◆ UPRIGHT TYPE
 ■ Maker / ZEN
 InLine Trail / 3 mm

◆ Ackerman

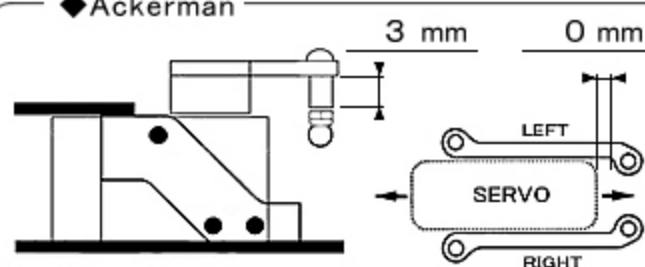

◆ Width / 198 mm ◆ Ride Height / 4.5 mm

◆ Front Spring / ZEN - Mid.

◆ Camber F104
 0° 1.0° 1.5° 2.0° 2.5°

◆ Toe IN OUT / 0.5°

◆ Front Tire / ZEN Hi-Rubber 55.5 mm

◆ Additive Yes No
 Maker /

Time ~ min / Width mm

◆ Notes

Rear

■ Rear Damper / AE-R5

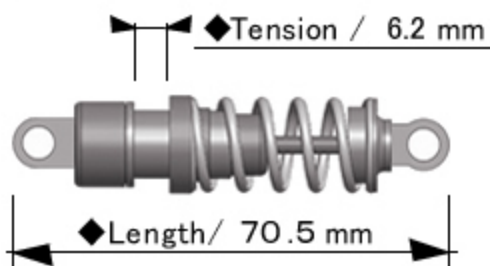

◆ Spring / YOKOMO-R12 Silver

◆ Piston / Hole ◆ Oil / # 400

■ Roll-Damper
 ◆ Length / 71.5 mm ◆ Oil / # 200

◆ Width / 200 mm

◆ Height Adapter



◆ Ride Height / 6 mm

◆ Rear Tire / ZEN Soft 25 56 mm

◆ Additive Yes No
 Maker /

Time ~ min / Width

◆ Body / TECH-MG10

◆ Rear Wing / TRG

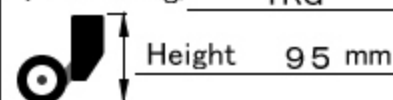

◆ Motor / JET-17.5T

◆ Spur / Pinion / RollOut
 90 T / 32 T / 63.08

◆ ESC / Hobby Wing

◆ Weight / 1077 g

◆ Steering Gyro
 Maker / ZEN

ON (GAIN 40 %)

◆ Notes

■ Side Link-Rod

